



USB/ RS-485 INTERFACE CONVERTER PD20



SERVICE MANUAL



List of Contents

1. APPLICATION.....	3
2. CONVERTER SET.....	3
3. INSTALLING THE CONVERTER.....	3
3.1. Converter assembly.....	3
3.2. Converter pinout configuration.....	4
3.3. COM port installation for Windows.....	5
3.4. Installation of COM port drivers on a computer.....	5
4. DESCRIPTION OF THE OPERATION.....	6
5. TECHNICAL DATA.....	6
6. ORDERING CODE.....	7
7. MAINTENANCE AND SERVICING.....	8

1. APPLICATION

The PD20 converter is a device that transfers data from the USB interface to the industrial RS-485 interface. The first interface is USB - it is designed to communicate with a device that has a USB Host port, which is usually a PC. The second interface is RS-485, intended for communication with devices on the facility side. The converter provides standard transmission speeds of up to 115.2 kbps, with the speed depending on the length of the cables used. The converter does not interfere with the structure of the transmitted data and is compatible with many industrial communication protocols, such as: Modbus RTU, Modbus ASCII, etc. In order to protect the devices on both sides of the interfaces, the converter uses galvanic isolation.

2. CONVERTER SET

The PD20 converter kit includes:

- PD20 converter 1 pc.
- RS485 interface connector for transmission cables 1 pc.

3. INSTALLING THE CONVERTER

3.1. Converter assembly.

The converter is a portable device powered by the USB bus. In order for the RS-485 interface to be used, a connector for the transmission cables must be installed in the device (Fig. 1). **This should be done before connecting the converter to the computer's USB port.**

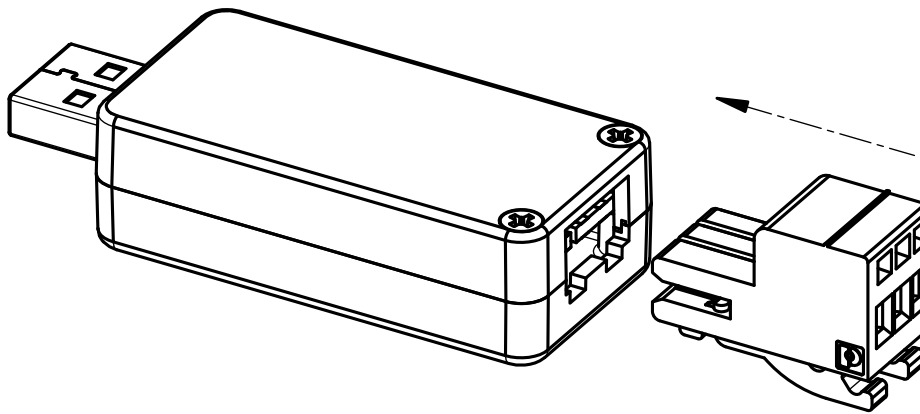

Fig. 1. Installation of connectors for transmission cables in the PD20 converter.

The dimensions of the assembled converter are shown in Fig. 2.

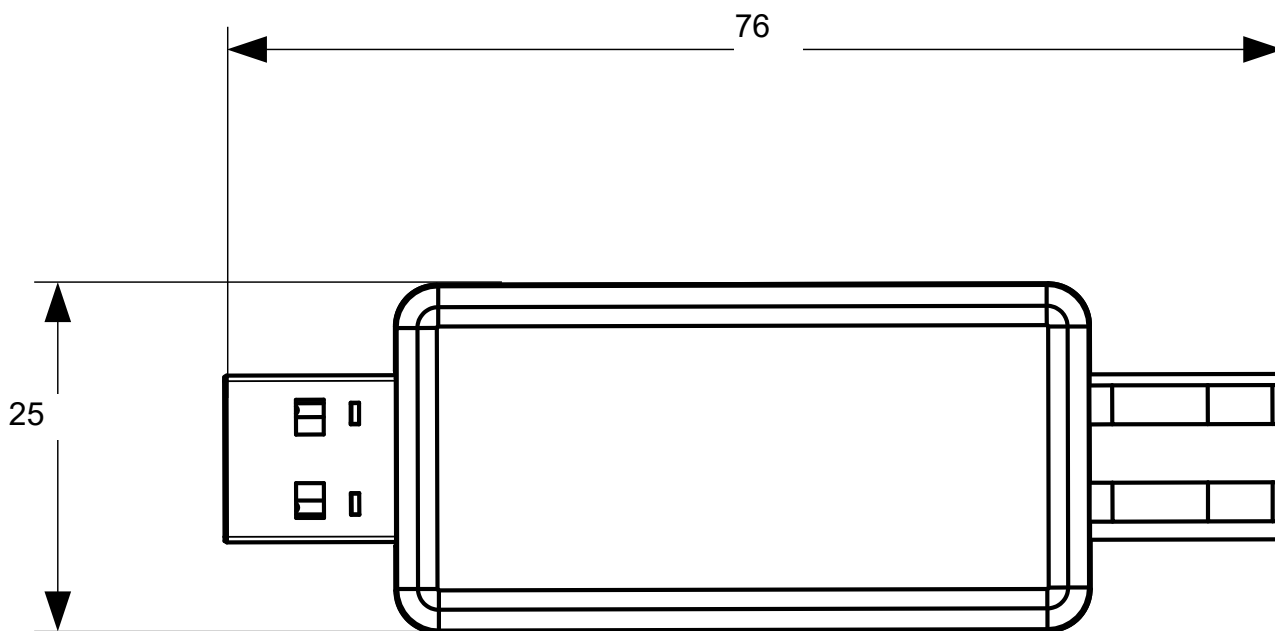

Fig. 2. Dimensions of the PD20 converter.

3.2. Converter pinout configuration.

PD20 converter pinout configuration is described in Fig. 3.

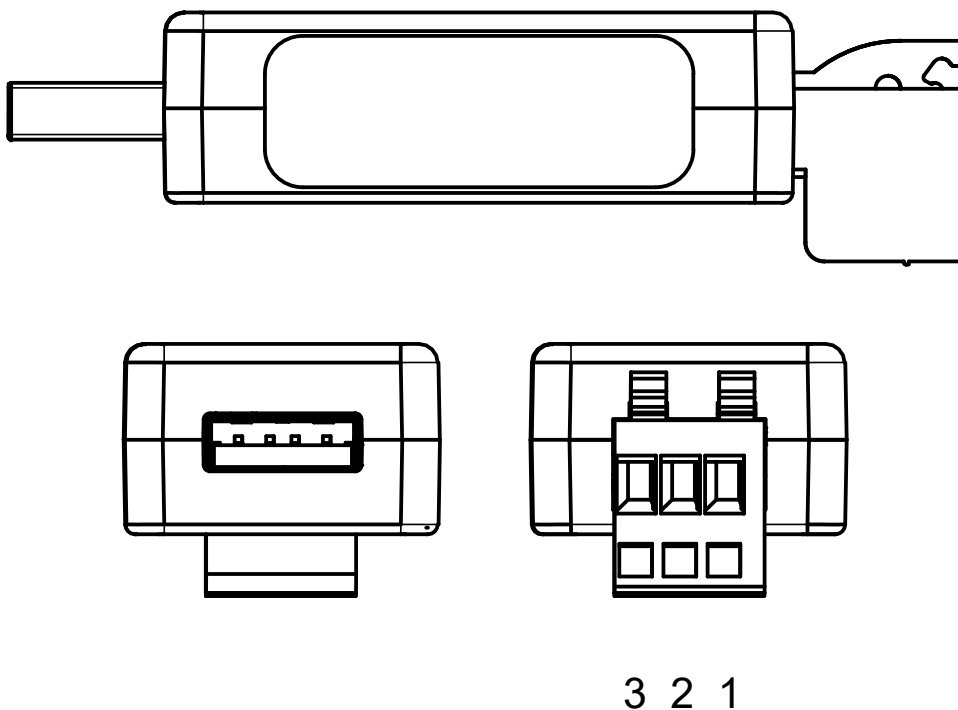

Fig. 3. PD20 converter pinouts.

External signals should to be connected in accordance with Table 1 which describes the purpose of the individual pinouts.

The converter features three indicator lights (shown in order from the USB connector):

- Green (RDY)** – indicates that the device is ready for data transfer
- Red (RXD)** – indicates that data is being received in the RS485 interface port
- Yellow (TXD)** – indicates transmission of data to the device connected to the RS485 interface

Table 1. RS485 interface pinouts.

RS485 Pin No.	Pinout configuration
1	Line A
2	Line B
3	GND line

3.3. COM port installation for Windows.

PD20 converter uses the CH341.SER drivers licensed by Nanjing Qinsheng Microelectronics Co. (available at www.wch.cn). This software creates a virtual COM port in the system called **USB-SERIAL CH341A**.

Installing the driver in Windows adds another COM serial port to the list of ports supported by the operating system.

3.4. Installation of COM port drivers on a computer.

After connecting the converter to the USB port the operating system should inform about automatic installation process of the converter drivers. The drivers are compatible with systems: Windows XP/Vista/7/8/8.1/10/11 and Windows Server 2003/2008/2012/2016/2019/2022 (32/64-bit). This process may vary in duration depending on the operating system in use. It is also possible to manually install/deinstall the device driver - the installer software along with the driver can be downloaded from the manufacturer's website:

http://www.wch-ic.com/downloads/CH341SER_ZIP.html

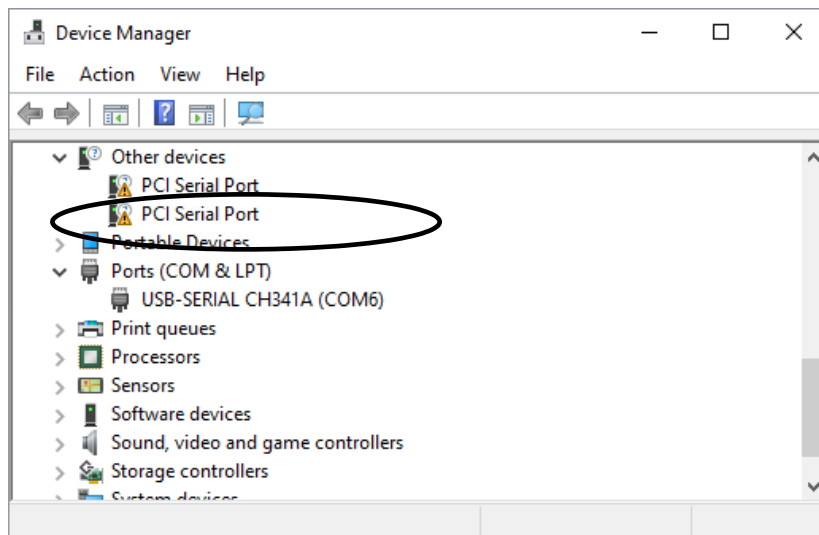

Fig. 4. Correct installation of the PD20 converter in Windows.

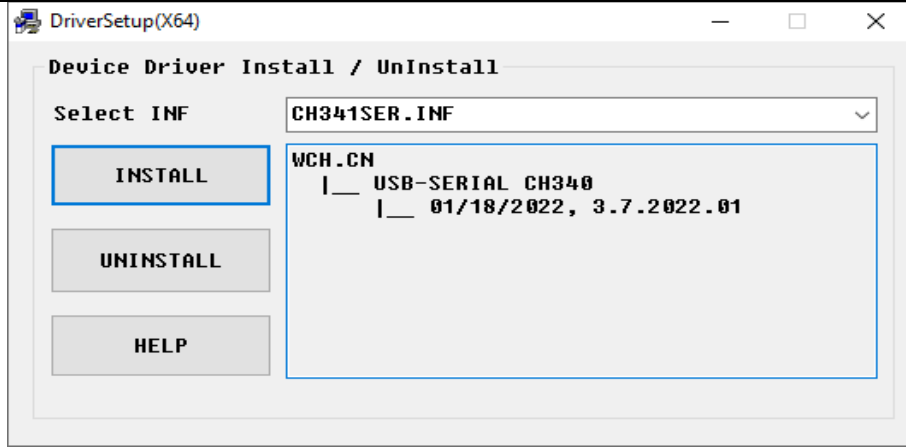

Fig. 5. Manual installation of the device driver.

4. DESCRIPTION OF THE OPERATION

The RS485 standard allows *half duplex* data transfer. This means that data can either be transmitted or received at any one time.

PD20 converter can operate at transmission rates of up to 115.2 kbps (depending on the length of the transmission line).

In an environment with unknown levels of interference, compliance with the following rules is recommended:



- connect the communication interface circuits individually in the screen with twisted wires,
- as a general rule, wires (beams) leading different signals should be routed as far apart from each other as possible (not less than 50 cm), and the intersections of such beams should be made at 90° angle.
- The device does not comply with the requirements for electromagnetic compatibility in a residential environment.

5. TECHNICAL DATA

Communication parameters

- baud rate Up to 115.2 kbps
- controlling the direction of data flow Automatic
- drivers Windows XP/Vista/7/8/8.1/10/11, Windows SERVER 2003/2008/2012/2016/2019/2022 (32/64bit)
- USB standard USB 2.0 (Full Speed)

Galvanic isolation USB/RS485

2,2 kV

Power consumed by the converter

≤ 1,5 W

Rated operating conditions:

- power supply voltage 5V DC, from USB port
- ambient temperature 0...40°C
- relative air humidity < 85% (without vapour condensation)
- service position any

Storage and transport conditions:

- ambient temperature 0..70 °C
- relative air humidity < 85% (without vapour condensation)

Rating of provided protection (EN 60529):

- housing side IP40
- pinout side IP20

Dimensions

76 x 25 x 20 mm

Weight

Approx. 20 g

Electromagnetic compatibility:

- noise immunity according to standard EN 61000-6-2
- noise emission according to EN 61000-6-4
- immunity in industrial electromagnetic environments according to EN 61326-1 (Table 2)

Maximum operating voltage to earth value: < 50 V**Pollution level:** 2**6. ORDERING CODE**

Table 2. PD20 ordering code

Converter	PD20	XX	X	X
Type of design				
standard		00		
special *		XX		
Version				
Polish and English			M	
other			X	
Delivery tests:				
without additional requirements				0
with additional quality control certificate				1
with calibration certificate				2
as agreed with the customer				X

* - after relevant agreement with the manufacturer

Code example:

PD20-00M0 code means converter in standard version, without additional requirements, in Polish and English language version

7. MAINTENANCE AND SERVICING

The PD20 converter does not require periodic maintenance. In the event of damage, the converter should be sent to the manufacturer's service department for repair.

LUMEL

**LUMEL S.A.**

ul. Słubicka 4, 65-127 Zielona Góra, Poland
tel.: +48 68 45 75 100, fax +48 68 45 75 508
www.lumel.com.pl

Informacja techniczna:

tel.: (68) 45 75 140, 45 75 141, 45 75 142, 45 75 145, 45 75 146
e-mail: sprzedaz@lumel.com.pl

Realizacja zamówień:

tel.: (68) 45 75 150, 45 75 151, 45 75 152, 45 75 153, 45 75 154, 45 75 155
fax.: (68) 32 55 650

Wzorcowanie:

tel.: (68) 45 75 163
e-mail: laboratorium@lumel.com.pl

Technical support:

tel.: (+48 68) 45 75 143, 45 75 141, 45 75 144, 45 75 140
e-mail: export@lumel.com.pl

Export department:

tel.: (+48 68) 45 75 130, 132
e-mail: export@lumel.com.pl

Calibration & Attestation:

e-mail: laboratorium@lumel.com.pl